

WP Series

Wire Processing



Expand the possibilities of your cable cutting machine

Positioned printing on cables –
reliable, comfortable and ready for future challenges



WP Series Wire Processing

Expand your possibilities

- > Use WP Series to turn your cutting machine into a cut & code system.
- > Set up text and position on your cable at the printer or from an easy to use PC programme.
- > No matter which cable colour or material you want to print on - choose from a wide range of high contrast inks offering the opacity, adhesion and offset properties you need.

Stay flexible

- > Save set-up time through easy cable data transfer and switching between cutting machines.
- > Combined with the WP Series Extension Set, WP Series guides your cables safely and precisely.
- > You need to code on parts such as plug connectors, as well? No problem. Switch WP Series to CS Series mode and use all CS Series functionalities - see CS Series brochure for details.

More time for production

Reliable and comfortable

- > Excellent contrast on all cable colours through heavy pigmented inks kept in dispersion by proven hydraulics system - also in Standby mode.
- > Seamless Start-Stop behaviour enabled by nozzle-sealing technology.
- > Quickly set up single cables or cable lists using the WP Cable software that comes with every WP Series printer.

Schematic setup of cutting machine with WP printer

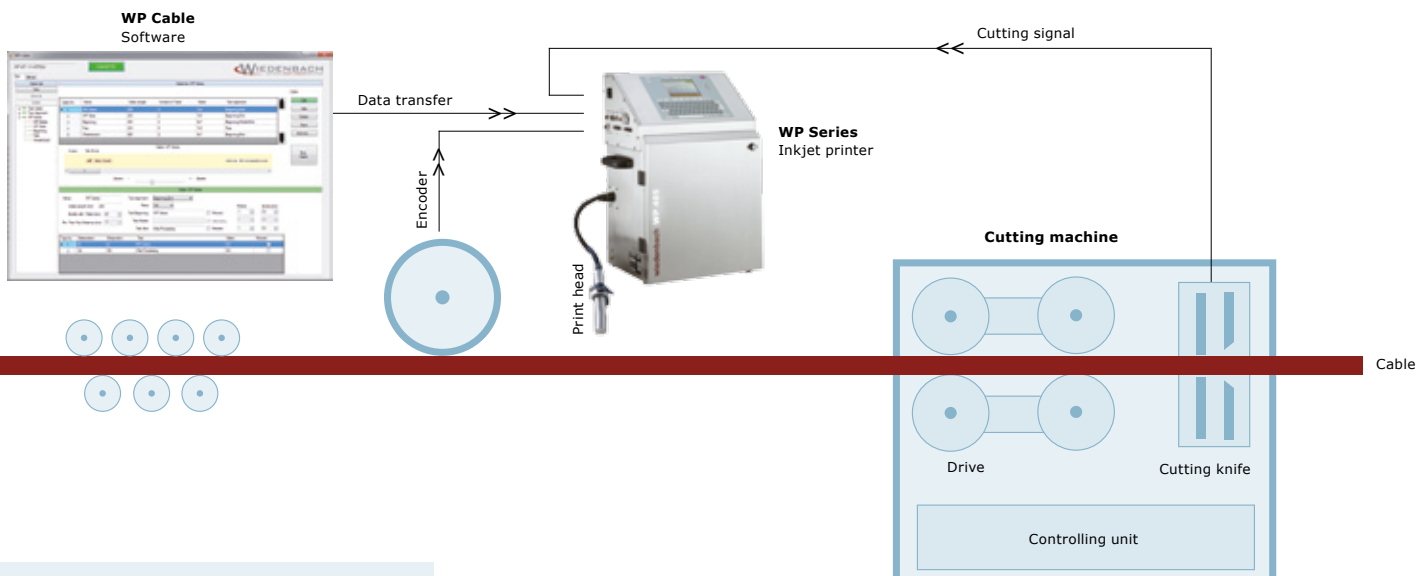

WP-Cable

Text creation and management

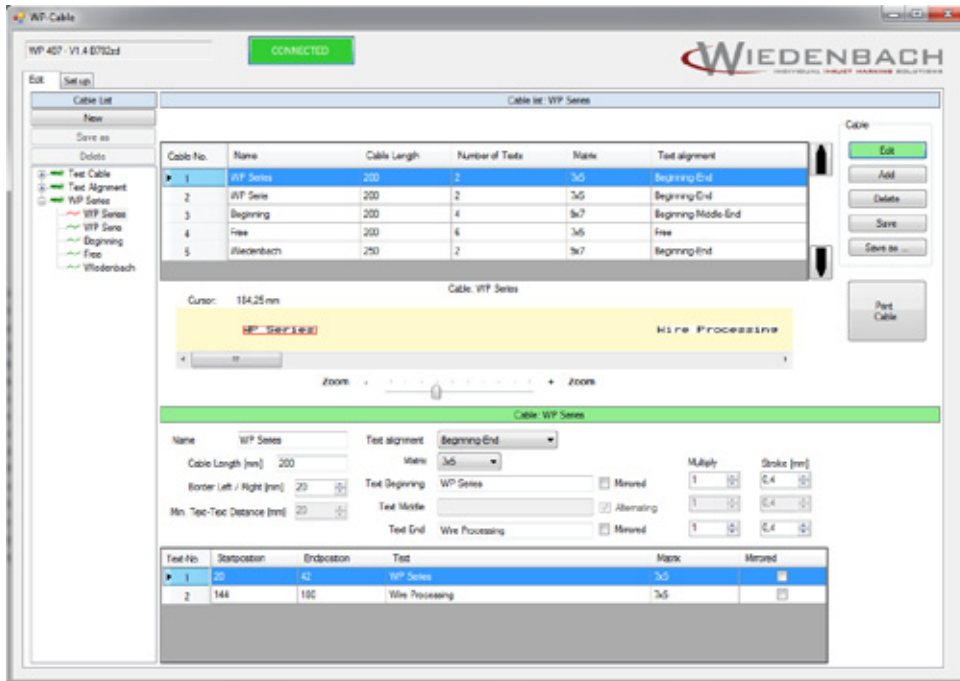

- > Edit your text comfortably with the PC software WP-Cable, which comes with every WP Series printer.
- > Position text as your customer wants: beginning/end, beginning/middle/end or free - WP-Cable helps you to do so.
- > Use symbols or automatic fields, such as counters or date in your printing text.
- > Vary your text: bold, length, vertical or mirrored.
- > Edit text and immediately see how it's going to print, with the WYSIWYG-display.
- > Fast data transfer over TCP/IP
- > Dual language (english/german)

Example of use

Customer X sent an order for a harness containing the following cables:

Cable Name	Lot-size	Length (mm)	Text Beginning	Text Middle	Text End
A	5	300	A-300	--	A-300 End
B	1	500	B-500	Counter 1234	End
C	10	800	C-Beginning	© Symbol	--

Workflow:

1. Cable set-up with text and position using the WP-Cable software. This can be done during process planning, away from the cutting machine.
2. Insert raw material for „cable A“ into cutting machine, set cable length to „300 mm“ and lot-size to „5“.
3. Selection of „cable A“ in cable list of WP-Cable Software and transmission to printer.
4. Start of cable production at cutting machine. WP Series prints the text on the predefined positions, triggered by the detected cutting signal of the cutting machine.
5. After printing of cable number 5 lot A is complete.
6. Repetition of steps 2-5 for cables B and C to complete order.

Result:

Cable A	A-300	A-300 End
Cable B	B-500	Counter 1234 End
Cable C	C-Beginning	© Symbol

Printer functionalities

- > Positioned cable printing: text alignment at beginning/end, beginning/middle/end or completely free
- > Single line text, with 5 to 23 dot raster, 1-12 mm print height
- > Prints on all cable colours with excellent contrast
- > ANSI and special characters
- > Text, symbols and counters (or combinations thereof)
- > Positioning accuracy: +/- 2 mm at 240 m/min printing speed
- > Print position entry in mm/inch
- > Access to all CS Series functions, e.g. for parts marking (see CS Series brochure)

Integration

- > Easy integration with existing cutting machinery.
- > Requires assembly of an optical or inductive cutting sensor, see 3-D sketch. Alternatively a cutting signal straight from the cutting machine can be used - if existent.
- > The obligatory encoder can be installed at an existing cable guiding unit or at the optional WP Series Extension Set.

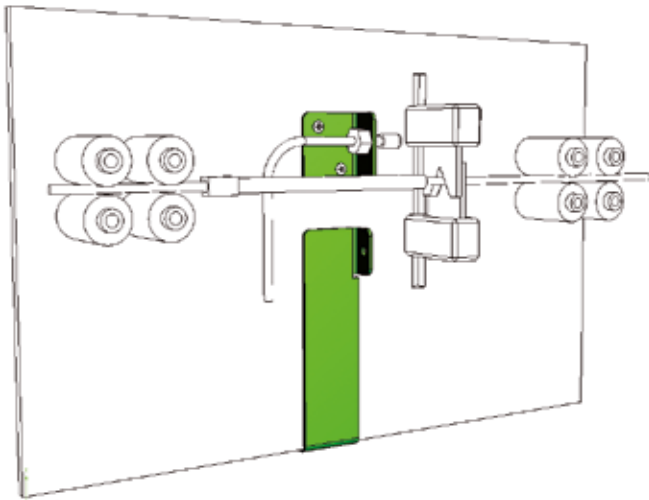

Your local Wiedenbach representative:

Technical data subject to change without prior notice.

Fit for production

- > The best inkjet solution for your cut and code application, enabled by 25 years experience with design and manufacture of inks and inkjet printers.
- > Global service and support network - to keep your production running.
- > What can we do for you? Please contact us and we're happy to assist.

Accessories

- > WP Series Extension Set for precise cable guidance
- > Sensors for cutting signal detection
- > Encoders for accurate positioning
- > Stainless steel trolley table
- > Indication light for printer status visibility

For more info please refer to the WP Series Accessories brochure.



WIEDENBACH
INDIVIDUAL INKJET MARKING SOLUTIONS

Wiedenbach Apparatebau GmbH
Industriepark 312, 78224 Gottmadingen, Germany
Tel +49 (0) 7731 79911-0, Fax +49 (0) 7731 79911-91
infoservice@wiedenbach.com, www.wiedenbach.com

 **DOMINO** GROUP COMPANY